



Main Features

- Excellent repeatability
- Dead band adjustment for regulation
- Fix dead band for control and alarm
- Explosion proof Hazardous areas 1, 2, 21, 22

Applications

- Power generation safety equipment

Technical Data

Temperature range	-46 ... 0 °C to 40 ... 120 °C		Electrical connection	Terminal block with metallic cable gland for Ø 7 to 12 mm standard
Temperature	Process:	-46 ... +120 °C	Electrical function	See ordering code details on page 5
	Ambient:	-30 ... + 55 °C	Adjustment	2 external adjustment screws on top of the case for set point and dead band
	Storage:	-40 ... + 55 °C	ATEX	<u>Type examination certificate</u> LCIE 03 ATEX 6231X (Type RA80) EN 60079-0: 2012 (internal conformity analysis) EN 60079-1: 2007 EN 60079-31: 2009
Repeatability	± 1% F.S. / constant temperature cycle		<u>Marking</u>	CE 0081 Ex II 2 G D Ex d IIC T6 or T5 Gb Ex t IIIC IIC T80 °C or T95 °C Db IP6X
CE conformity	Low Voltage Directive LVD 2006/95/EC ATEX Directive 94/9/EC		<u>T° ambient</u>	-20 °C to +60 °C (T6 or T80 °C) or -20 °C to +70 °C (T5 or T95 °C)
Protection rating	IP 66 (EN 60529)			
Process connection	RTA:	Copper alloy		
	RTN:	Stainless steel 1.4404 (316L)		
Bulb	RTA:	Copper alloy		
	RTN:	Stainless steel 1.4404 (316L)		
Scale	Internal. Accuracy on reading ± 5% F.S.			
Housing	Type RA80, explosion proof, flameproof Aluminium epoxy painted. Captive stainless steel screws			
Mounting	3 back lugs for wall mounting			
Ground connection	Via internal terminal block			

Options

Customer specific set point adjustment	Code SETP
Stainless steel tag plate and wire	Code 9941
Lead seal of the adjustment screws	Code 8990
Nuclear cleanliness (RTN only)	Code 0838

Principle

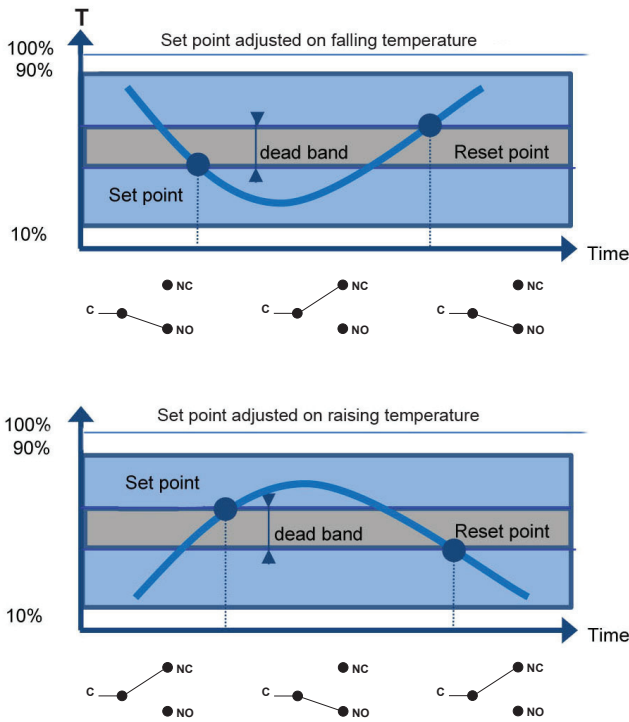

A vapour filled flexible sensing element actuates a microswitch by means of a lever. The set point is adjusted by means of a compressible spring installed in opposition.

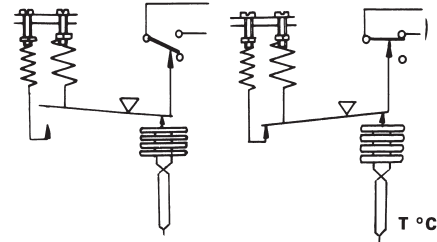

Set point and reset point must be between 10% and 90% of the selected scale.

Standard factory adjustment

Setpoint at 50% of the scale on falling temperature

Customer specific factory adjustment (option SETP)

The following specifications have to be given with the order:

- Setpoint value
- Adjustment on falling or raising temperature
- Dead band value (as needed) when using an adjustable dead band switch

Electrical connections

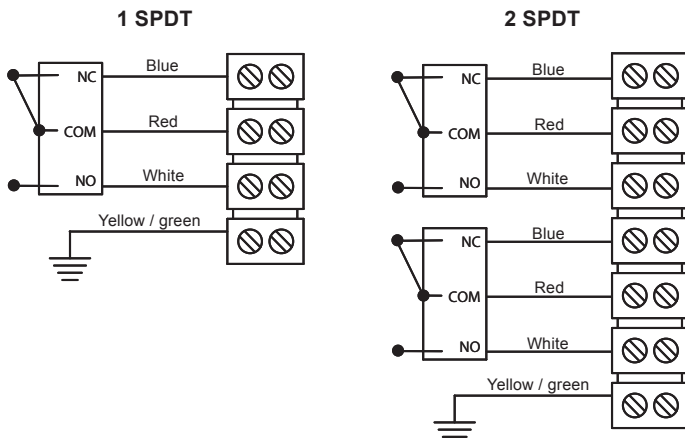

Hazardous areas: 1, 2, 21, 22

-20 °C ≤ Ta ≤ +70 °C	Dust IP6x	Gases
	T° surface	Class
Ta = 60 °C	80 °C	T6
Ta = 70 °C	95 °C	T5

Important: Maximum power dissipation in the case must not exceed 5 W

All necessary measures must be taken by the user, to avoid the calorific transfer from the fluid to the apparatus head increasing the head's temperature to such that it reaches the self-ignition temperature of the gas in which it is used.

Micro switches characteristics

Switch code	A (B)	M (K)	C (W)	E (F)	D (V)
Type	Standard	Gold contact	Hermetic	Ultra sensitive	Ultra sensitive Hermetic
6 Vdc	0.4 ... 10 A	10 ... 50 mA	5 mA ... 4 A	0.4 ... 1 A	0.4 ... 4 A
12 Vdc	0.4 ... 10 A	10 ... 50 mA	5 mA ... 4 A	0.4 ... 1 A	0.4 ... 4 A
24 Vdc	0.4 ... 6 A	10 ... 50 mA	5 mA ... 4 A	0.4 ... 1 A	0.4 ... 4 A
30 Vdc	0.4 ... 6 A	10 ... 10 mA	5 mA ... 3 A	0.4 ... 1 A	0.4 ... 2 A
48 Vdc	0.4 ... 6 A	10 ... 50 mA	5 mA ... 3 A	N/A	N/A
110 Vdc	0.1 ... 0.5 A	10 ... 50 mA	5 mA ... 1 A	N/A	N/A
220 Vdc	0.1 ... 0.25 A	10 ... 50 mA	5 mA ... 0.5 A	N/A	N/A
115 Vac	0.4 ... 10 A	10 ... 50 mA	50 mA ... 3 A	0.4 ... 10 A	N/A
250 Vac	0.2 ... 10 A	10 ... 10 mA	50 mA ... 2.5 A	0.2 ... 10 A	N/A
Dielectric rigidity between contacts and ground	2000 V	2000 V	1500 V	2000 V	1000 V

Adjustable ranges

Scale	T _{Max} accidental	Code	Micro-switch dead band ⁽¹⁾									
			Adjustable dead band				Fixed dead band					
			A (B*)		M (K*)		C (W*)		E (F*)		D (V*)	
			10%	90%	10%	90%	10%	90%	10%	90%		
°C			°C									
-46 ... 0	40	300	6 - 13	3 - 13	12 - 18	6 - 18	2.25	1.2	7.5	3.7		
-20 ... 20	60	301	4.5 - 12	2.2 - 12	9 - 15	6 - 15	1.5	0.75	6	3		
0 ... 45	60	302	6 - 13	3 - 13	10 - 18	6 - 18	2.25	1.05	7.5	3.7		
40 ... 120	145	303	7.5 - 24	4.5 - 24	15 - 30	9 - 30	3	1.8	9	6		
20 ... 80	100	315	7.5 - 18	4.5 - 18	13 - 22	7.5 - 22	3	1.5	9	4.5		

(*) For version with 2 microswitches lower values of the dead band must be multiplied x 1.5

⁽¹⁾ The value of the dead band is depending on the value of the set point.

This table contains the dead band values for set point adjustment at 10% and 90% of the selected scale. For adjustable dead band the lower value corresponds to the dead band spring totally released and the higher corresponds to the dead band spring fully tensed. For other set points the dead band value can be calculated by linear interpolation between the values at 10% and 90%.

Dimensions (mm)

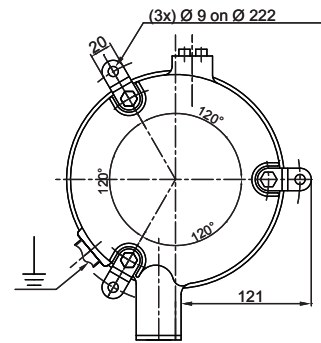
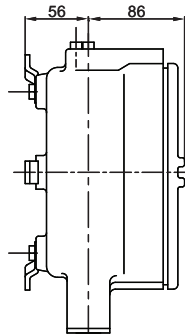
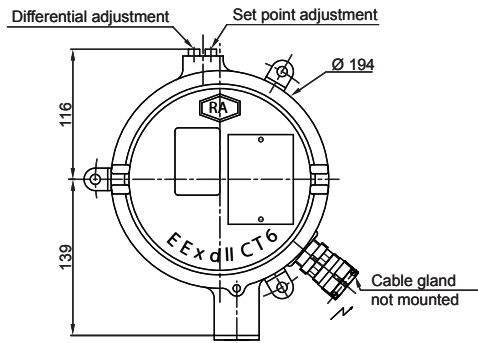

Weight of the housing: 4.4 kg

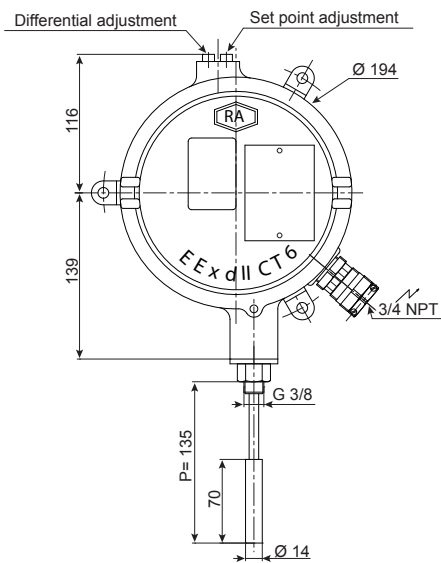

Thermowell
Thermowell for RTxx3
Stainless steel
Ordering code: 10271317

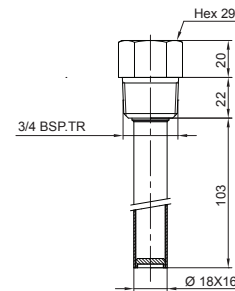

Ordering details RTNE3 - RTAE3

	RT	-	E	.	3xx	.	E	0	0	E	J	/
Model	Industrial temperature switch											
Type of the bulb	Copper alloy bulb											
	Stainless steel bulb											
Approvals	ATEX explosion proof											
Type of micro switches	1 SPDT standard changeover switch											
	2 SPDT standard changeover switch											
	1 SPDT hermetically changeover switch											
	2 SPDT hermetically changeover switch											
	1 SPDT ultra sensitive changeover switch											
	2 SPDT ultra sensitive changeover switch											
	1 SPDT hermetically, ultra sensitive changeover switch											
	2 SPDT hermetically, ultra sensitive changeover switch											
	1 SPDT gold contact changeover switch											
	2 SPDT gold contact changeover switch											
Temperature range (°C)	-46 ... 0											
	-20 ... 20											
	0 ... 45											
	40 ... 120											
	20 ... 80											
Type of design	Direct mounting (TRD)											
Capillary length	Without capillary											
Stem length P	P=135 mm											
Bulb diameter	Ø 14 mm											
Process connection	G3/8											
Options to be added behind the / (see example below)												

Ordering example with options

	RT	-	A	E	A	.	300	.	E	0	0	E	J	/	SETP	-	9941	
Industrial temperature switch	←																	
Copper alloy bulb	←																	
With ATEX explosion proof	←																	
1 SPDT standard changeover switch	←																	
Temperature range -46 ... 0 °C	←																	
TRD direct mounting	←																	
Without capillary	←																	
Immersion length P=135 mm	←																	
Bulb diameter Ø 14mm	←																	
Process connection G3/8	←																	
Option: Customer specific set point adjustment	←																	
Option: Stainless steel tag plate and wire	←																	